

1) Given the finite state machine $(\mathcal{I}, \mathcal{O}, S, f, g, \sigma)$ with $\mathcal{I} = \{a, b, c\}$, $\mathcal{O} = \{0, 1, 2\}$, $S = \{A, B, C\}$, $\sigma = A$, and f, g as described in the table below, draw the corresponding transition diagram. (10 points)

	f			g		
$S \setminus I$	a	b	c	a	b	c
A	A	B	A	0	1	0
B	B	B	A	1	1	0
C	A	C	B	0	2	1

2) Given the transition diagram for a finite state machine below, give the output corresponding to the input "abbc". (10 points)

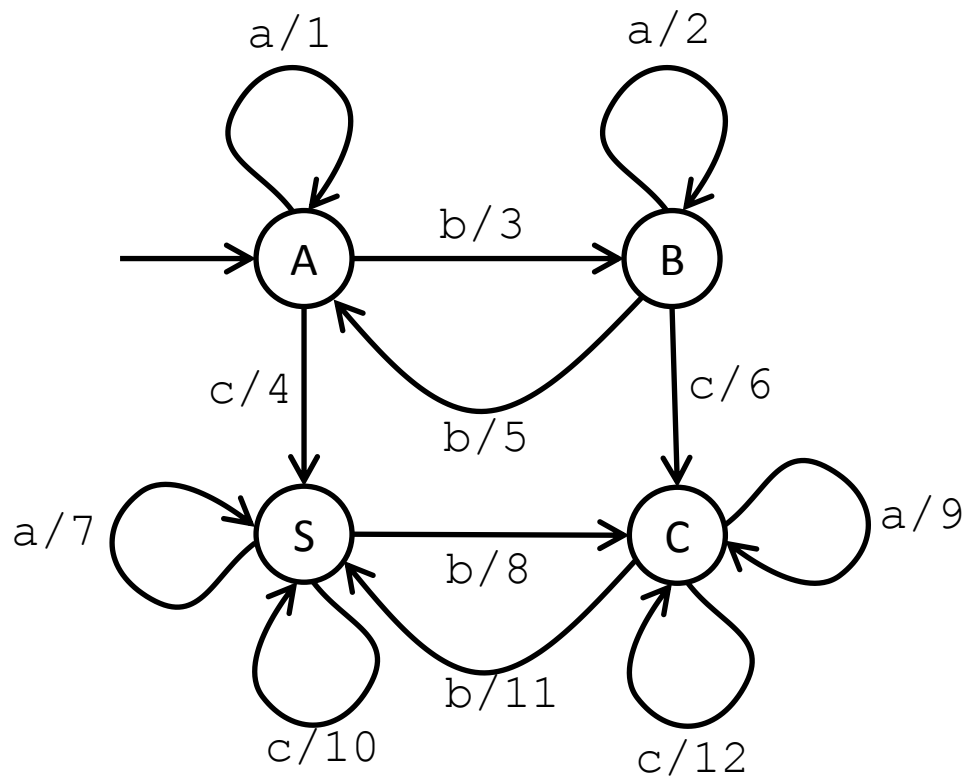

3) Given the finite state automata shown below, is the string "abcabcbbb" accepted? Show your work or justify your answer. (5 points)

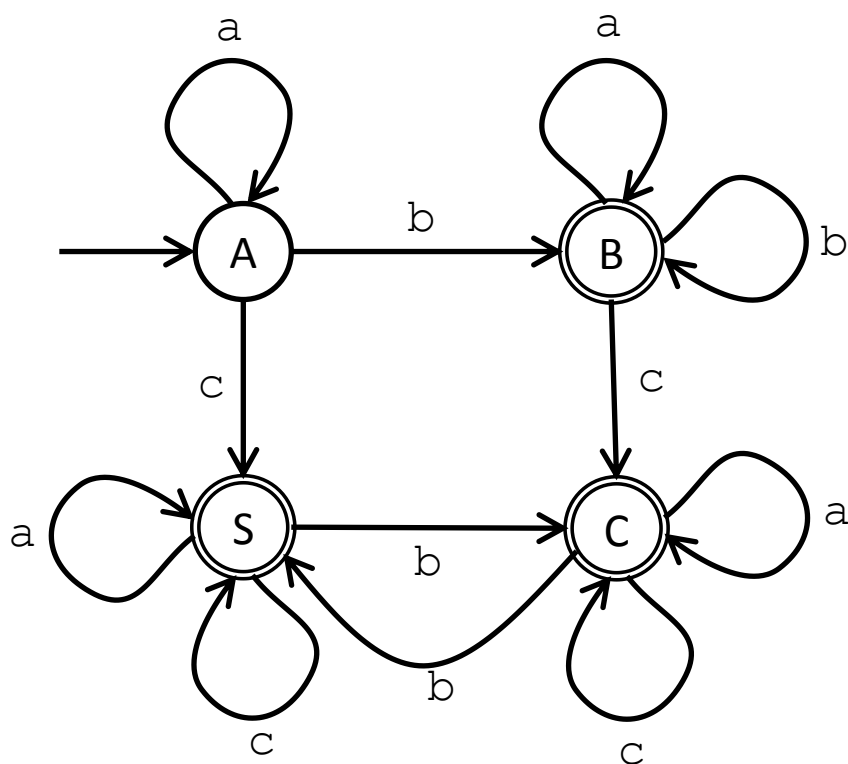

4) Given the finite state automata $(\mathcal{J}, S, f, \mathcal{A}, \sigma)$ defined in the previous question, formally define each of the sets \mathcal{J} , S , and \mathcal{A} . (5 points)

$\mathcal{J} =$

$S =$

$\mathcal{A} =$

5) Given the grammar $G = (N, T, P, \sigma)$ with $N = \{A, B\}$, $T = \{a, b, c\}$, $\sigma = A$, and P consisting of the productions below, give a derivation to show that $abaca \in L(G)$. (10 points)

$$A \rightarrow a|b|aA|aB$$

$$B \rightarrow aB|bB|cA$$

6) Below are the productions for 5 grammars. Each one uses the same set of nonterminal symbols, $N = \{A, B\}$; terminal symbols $T = \{a, b, c\}$, and starting symbol $\sigma = A$. For each one determine whether it is regular, context free, context sensitive, or none of these. If there are multiple correct answers, give the most specialized. (For example, if a polygon is both a square and a rectangle, we say it is a square.) (2 points each)

$$A \rightarrow a|b|aA|aB$$

$$B \rightarrow aB|bB|cA$$

- (a) Regular (b) Context Free (c) Context Sensitive (d) None of These
-

$$A \rightarrow a|b|aB|aA$$

$$aA \rightarrow a|b|aB|aA$$

$$B \rightarrow aB|bB|A$$

- (a) Regular (b) Context Free (c) Context Sensitive (d) None of These
-

$$A \rightarrow a|b|aB|aA$$

$$aAb \rightarrow aBb|aAbb$$

$$bBbc \rightarrow bBbc|bAbc$$

- (a) Regular (b) Context Free (c) Context Sensitive (d) None of These
-

$$A \rightarrow a|b|Aa|Ba$$

$$B \rightarrow a|b|BA$$

- (a) Regular (b) Context Free (c) Context Sensitive (d) None of These
-

$$A \rightarrow a|b|Aa|Ba$$

$$B \rightarrow a|b|Ba$$

- (a) Regular (b) Context Free (c) Context Sensitive (d) None of These

7) Given the grammar $G = (N, T, P, \sigma)$ with $N = \{A, B\}$, $T = \{a, b, d\}$, $\sigma = B$, and P consisting of the productions below, create the transition diagram for a nondeterministic finite state automata that produces the same language. (10 points)

$$A \rightarrow a|bB$$

$$B \rightarrow b|aB|bA$$

8) Given the transition diagram for the nondeterministic finite state automata below, create the transition diagram for the corresponding deterministic finite state automata. (10 points)

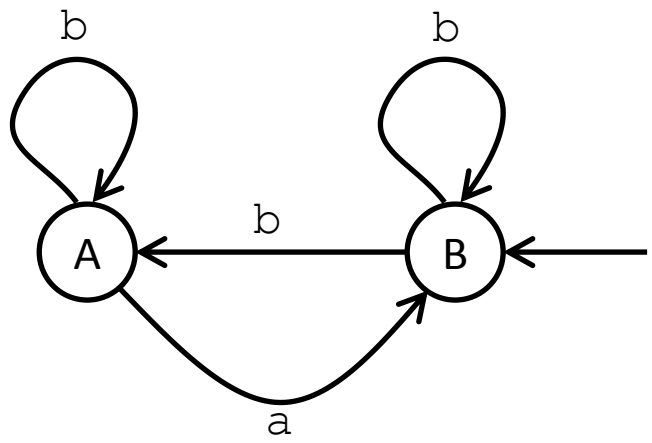

9) Given the transition diagram for the finite state automata below, create the corresponding grammar that defines the same language. (10 points. $N=1$ point; $T=1$ point; $\sigma=1$ point; $P=7$ points)

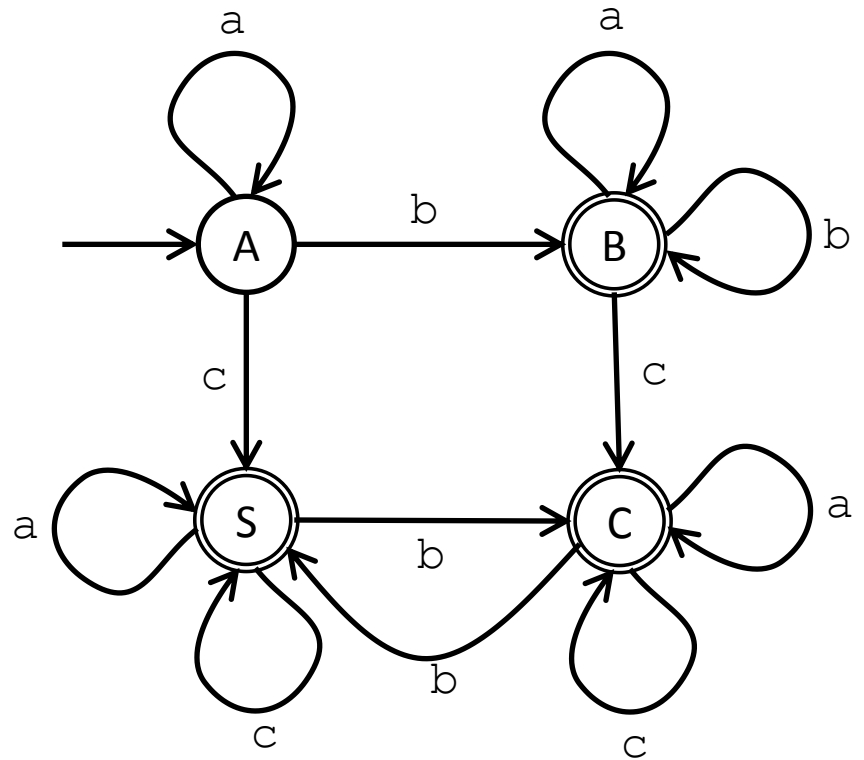

10) Given the infix expression below, create the binary expression tree that represents it. (5 points)

$$3 + 2 \cdot 4 \cdot 5$$

11) Evaluate the postfix expression below. (5 points)

$$2\ 6\ 5\ +\ 6\ -\ \div$$

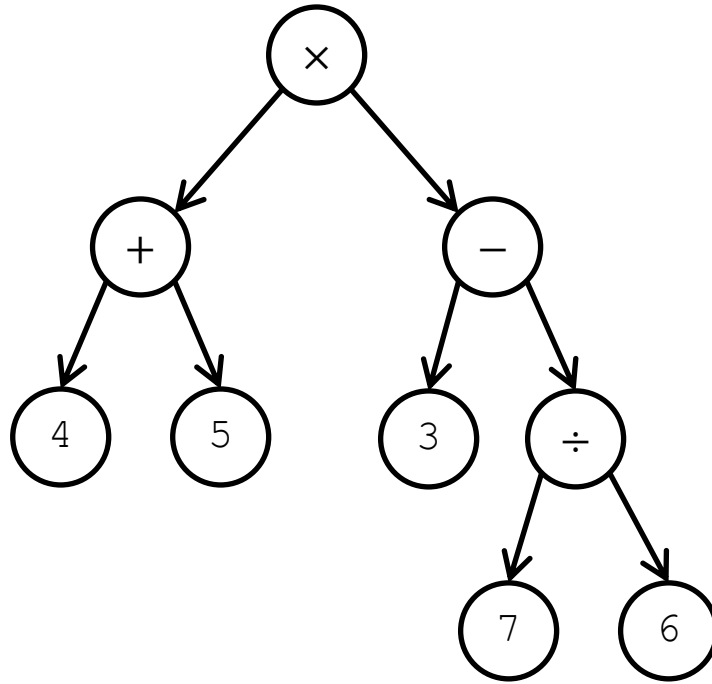

12) Given the expression tree above, write the corresponding mathematical expression in infix notation. (5 points) Remember to be mindful to add parenthesis where needed.

13) Given the expression tree above, write the corresponding mathematical expression in postfix notation. (5 points)