

Lab 09: Ohm's Law

INTRODUCTION

The concept of electrical resistance is both simple and complicated. The simple part: not everything is equally easy to push electrons through. Well, we know this. We already know that some materials are good conductors (like a copper wire), and some materials are pretty terrible (like the plastic insulation covering the wire). It's obvious to us that the copper has a lower resistance to electrical current, and the insulation has a higher resistance. The more complicated part is explaining exactly why copper (or any other good conductor of electricity) has low resistance.

We have observed that for a given light bulb, increasing the voltage increases the current (and the brightness). Now that we know a little about circuits, we can quantify this relationship. Ohm's Law states:

$$V = IR$$

We will measure the voltage and current in a circuit, and establish that this relationship is valid.

OBJECTIVES

- Correctly construct DC circuits based on schematic diagrams
- Demonstrate Ohm's Law quantitatively
- Learn to use the color-band system to identify standard resistors
- Distinguish between ohmic and non-ohmic behavior using a graphical representation

EXPERIMENTAL EQUIPMENT

- LabQuest unit
- DC power supply
- Circuit board
- Voltage probe
- Current probe
- Assorted wires

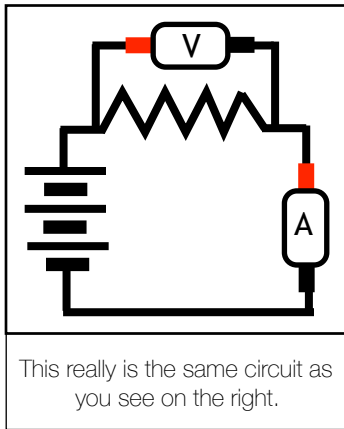

PROCEDURE

- Choose a resistor from the circuit board and record the colors of the bands printed on the resistor. Use the color code table to determine the resistance and tolerance.
- Please make sure that the power supply is switched off as you are completing your circuit.
- Use the diagram on the left to construct the circuit. The current probe (A) must be connected (+) to (+) and (-) to (-). It is not as important for the voltage probe (V) to be (+) to (+), but it will be less confusing for you if it is. Use the

photo on the left as well to help insure that you have the circuit wired properly.

- Attach the **voltage** probe to **Channel 1** of the LabQuest, and attach the **current** probe to **Channel 2**. Make sure that the unit recognizes both probes. Adjust the data acquisition time for an interval of **10 seconds**.
- Use the **Graph** menu to view only **Graph 1**, and adjust this graph to show **current** on the **x-axis**. You should have a graph displayed of voltage (y) as a function of current (x).
- The **current and voltage probes are extremely sensitive, and can be permanently damaged by overloading them**. The current probe will be literally destroyed by currents greater than **0.600A**. The voltage probe is limited to **6V**. It is more forgiving than the current probe, but you will render it permanently inoperable if you exceed **7V**. Please do not exceed these limits.

Band 1	Band 2	Band 3	4 - BAND	Band 4
VALUE	VALUE	MULTIPLIER		TOLERANCE
Band 1	Bands 2 & 3	Band 4	5 - BAND	Band 5
VALUE	VALUE	MULTIPLIER		TOLERANCE
BLACK 0	BLACK 0	BLACK x1 or no zeros		
BROWN 1	BROWN 1	BROWN x10 or +1 zero		BROWN ±1%
RED 2	RED 2	RED x100 or +2 zeros		RED ±2%
ORANGE 3	ORANGE 3	ORANGE x1k or +3 zeros		
YELLOW 4	YELLOW 4	YELLOW x10k or +4 zeros		
GREEN 5	GREEN 5	GREEN x100k or +5 zeros		GREEN ±.5%
BLUE 6	BLUE 6	BLUE x1M or +6 zeros		BLUE ±.25%
VIOLET 7	VIOLET 7			VIOLET ±.1%
GREY 8	GREY 8	GOLD x.1		GOLD ±5%
WHITE 9	WHITE 9	SILVER x.01		SILVER ±10%
VALUE	VALUE	MULTIPLIER		TOLERANCE

250Ω (±5%) = RED GREEN BROWN (GOLD)

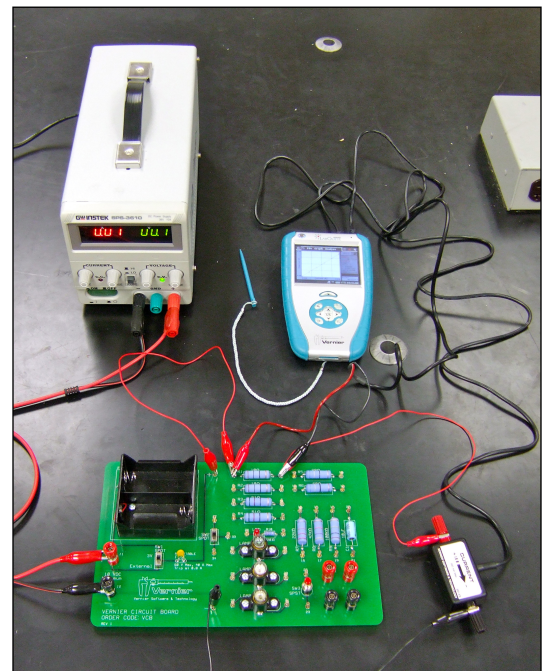

The electrons don't care if the wire is black or red, but color-coding the wires helps you see the direction of the circuit.

- It is necessary to set the power supply to limit the maximum current output. We will always use the power supply in constant voltage (CV) mode. The power supply has both coarse and fine adjustments for both current and voltage. It also has a **HI-LO** range selector.
- When the selected range is **LO**, the maximum current in CV mode will be **0.200A**. With the power supply off, zero all of the control knobs to the left (anti-clockwise). Now adjust only the **fine control** of the **current to maximum** (clockwise). The **coarse** control of the current remains at **zero**. When you switch the power supply on, you will adjust only the voltage to power your circuit. **The current will never exceed 0.200A. Note that you are not voltage-limited, so you must still be careful not to exceed 6V.**
- When the circuit is wired and the power supply is in the correct mode, begin to collect data. When you start the acquisition, slowly adjust the **fine voltage**, increasing it continuously for the 10 seconds of data collection. Keep an eye on the LabQuest, and make sure your voltage and current readings do not approach the limits. You might have to practice this a few times before you get a useable data run.
- Perform a curve fit on your data, and record the slope of the line. Save the run. You may need to re-examine the data or graph, so do not overwrite it with the next trial.
- Repeat for a second resistor, rewiring the circuit with the power supply switched off. When you have a second data set, again perform the linear regression and record the slope of the line. Again, save the data before you proceed.
- Repeat one more time, using one of the light bulbs instead of a resistor. Try to notice the point at which you begin to see the bulb glow.
- Notice that you cannot perform a single linear fit for the resulting data. Find the slope of the portion of the curve which is linear at the beginning of the trial, then adjust the range and re-fit the curve to find the slope of the data at the end of the trial. Sketch the shape of this curve in your notebook, and record both of the slopes.

DATA

If you have not already, organize your data into a neat table :

COLOR BAND	RESISTOR 1		RESISTOR 2	
	COLOR	VALUE	COLOR	VALUE
1				
2				
3				
TOLERANCE				
TOTAL RESISTANCE	R ₁ =		R ₂ =	
GRAPHICAL SLOPE	slope ₁ =		slope ₂ =	
% ERROR				

QUESTIONS

1. If you have not done so, sketch the graphs in your notebook, making sure to record the slopes. Make the connection between the slope and the resistance explicit (a higher resistance should be a steeper line). Also be sure to sketch the graph for the lightbulb as accurately as possible.
2. For each resistor, compare the slope of your graph to the known resistance R (read from the color bands). What is your % error in each case? Calculate and record the value for each resistor.

$$\%error = \left(\frac{R - slope}{R} \right) \times 100$$

3. Are you within the tolerance for these resistors? That is, is your % error smaller than the tolerance %? If not, why not (there are multiple possibilities here)?
4. Not all resistors are this well-behaved. The lightbulb, for example, is non-ohmic. Compare the slope of the curve at the beginning of the trial to the slope at the end. Is the resistance of the lightbulb constant? Does it increase or decrease with increasing current?
5. Explain why the resistance of the bulb changes. Think about how an incandescent lightbulb works, and when the bulb started to glow noticeably.